The Interaction of Attention & Emotion

JG Taylor & N. Fragopanagos

Dept of Mathematics, King's College London, UK

KING'S
College
LONDON

University of London

NEURAL NETWORKS 18(4):
EMOTION & BRAIN, 315-
435(May, '05)

Ed JG Taylor, K Scherer & R Cowie
(incl papers by L Canamera, S Kollias, L
Devillers, E Douglas-Cowie et al)

RECENT PRESS RELEASE:

(The Times, 26/06/05)

- “A pacemaker for the brain can lift the cloud of severe clinical depression from patients for whom other therapies fail, research at the University of Bristol has indicated. The technique, which uses electricity to turn down excessive activity in part of the brain, brought immediate improvements in mood to four of the six chronically depressed patients in the trial, allowing them to resume normal life.”
-

DEPRESSION

- => important new treatment in depression
 - Depression most common of all psychiatric disorders in society (40 million in US)
 - 20% not respond to standard treatment
 - Insert deep brain stimulators into cingulate
 - Based on brain architecture suggested by Helen Mayberg (Toronto)
 - Crucially observed brain architecture in moods
-

PROPOSED ARCHITECTURE:

- From brain imaging in patients:

Pre ↓ COGNITIVE CX ↑ Post

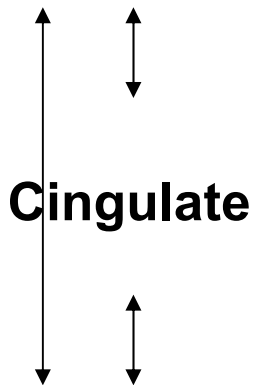

Cingulate as important mediator between cognition & emotion::
inappropriately active causes loss of drive & emotion colour in cognitive circuits

Pre ↑ LIMBIC CX ↓ Post

Regions of hypometabolism are shown in green; regions of greater glucose metabolic activity are shown in red. The image on the far left indicates regions of hypometabolism in depressed patients relative to healthy comparison subjects. The other three images depict pretreatment glucose metabolic activity in the rostral cingulate cortex (CG24a) in depressed subjects (relative to healthy subjects) who eventually (from left to right) responded to treatment, did not respond to treatment, and in the state of full remission. (Mayberg, 2002)

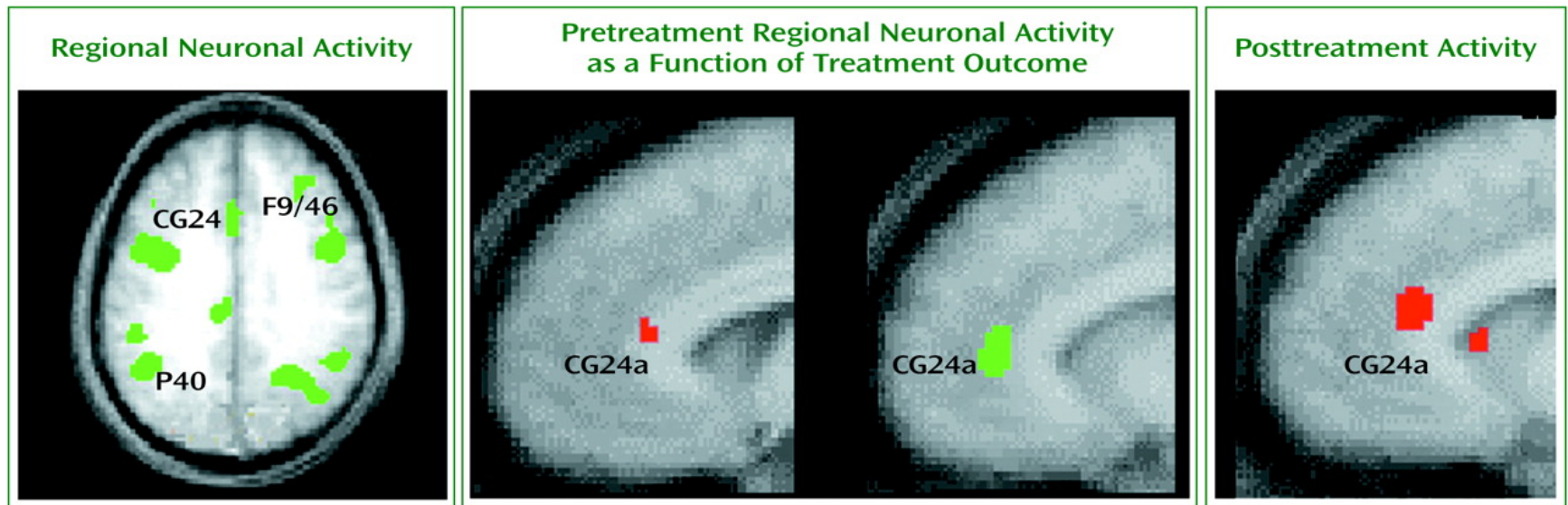

MAYBERG ARCHITECTURE

Limbic-Cortical Dysregulation Model

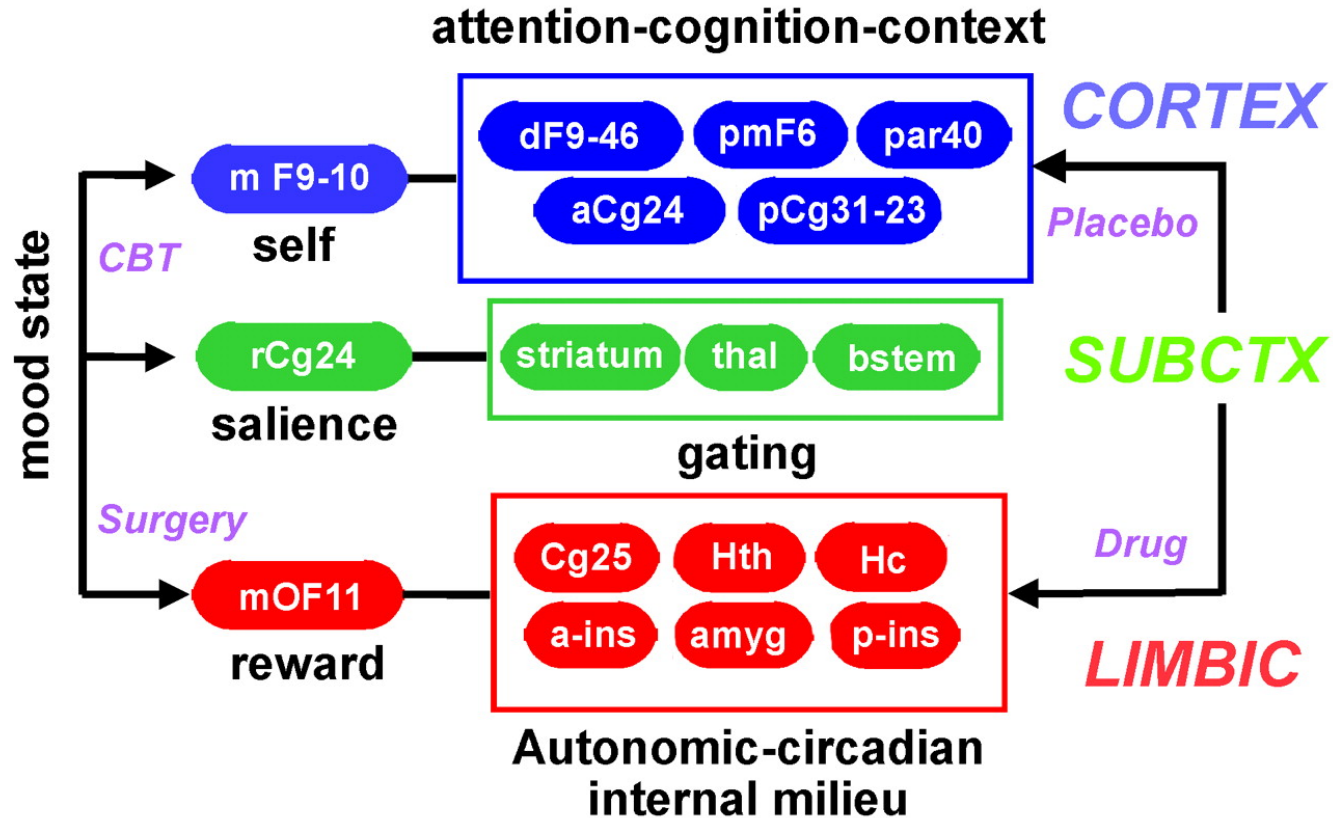

MAYBERG MODEL

- Limbic-cortical dysregulation model. Regions with known anatomical interconnections^{27–29}, that also show synchronized changes using PET in 3 behavioural states – base-line depressed (unipolar and Parkinson's disease patients), post-treatment (medication, cognitive therapy, placebo, surgery), and transient induced sadness (controls, patients, neurotics) – form the basis of this schematic. Failure of this regional network is hypothesized to explain the combination of clinical symptoms seen in depressed patients (*i.e.* mood, motor, cognitive, vegetative). Regions are grouped into 3 main compartments, cortical (blue), limbic (red) and subcortical (green). The frontal-limbic (dorsal-ventral) segregation additionally identifies those brain regions where an inverse relationship is seen across the different PET paradigms. Sadness and depressive illness are both associated with decreases in dorsal neocortical regions and relative increases in ventral limbic and paralimbic areas. The model, in turn, proposes that illness remission occurs when there is appropriate modulation of dysfunctional limbic-cortical interactions (solid black arrows) – an effect facilitated by various forms of treatment. It is further postulated that initial modulation of unique subcortical targets by specific treatments facilitates adaptive changes in particular pathways necessary for network homeostasis and resulting clinical recovery.

IMPLICATIONS

- => Relevance of relation between cognition and emotion: $CX \leftrightarrow$ Limbic, also through CG
 - How network functions not well understood: involves self-correction
 - Need to look in global manner at this interacting network, & model interaction
 - Emotions/moods not from single sites in brain
 - Relate to CPM & other models of emotion
-

MORE GENERAL QUESTIONS

- 1. How is cognition handled in the brain?**
 - 2. How is emotion handled in the brain**
 - 3. How do cognition ↔ emotion interact with each other in the brain?**
-
- APPROACH BASED ON KNOWN DATA:
BRAIN IMAGING & DEFICITS/DISEASE**
 - APPROACH BY MODELLING DATA**
 - COGNITION BASED ON ATTENTION**
-

MORE SPECIFICALLY: THE HUMANE QUESTIONS

- Model development?: As determined by experimental data (brain imaging/single cell)
 - Model purpose?: To understand interaction between brain systems (especially attention v emotion)
 - What deduced from model?: ANNA model of emotion recognition process (ERMIS)
 - Brain-based?: Yes, but not try model complete brain
 - Not involved with virtual characters
-

The Component Process Model of Appraisal (CPM: K Scherer et al)

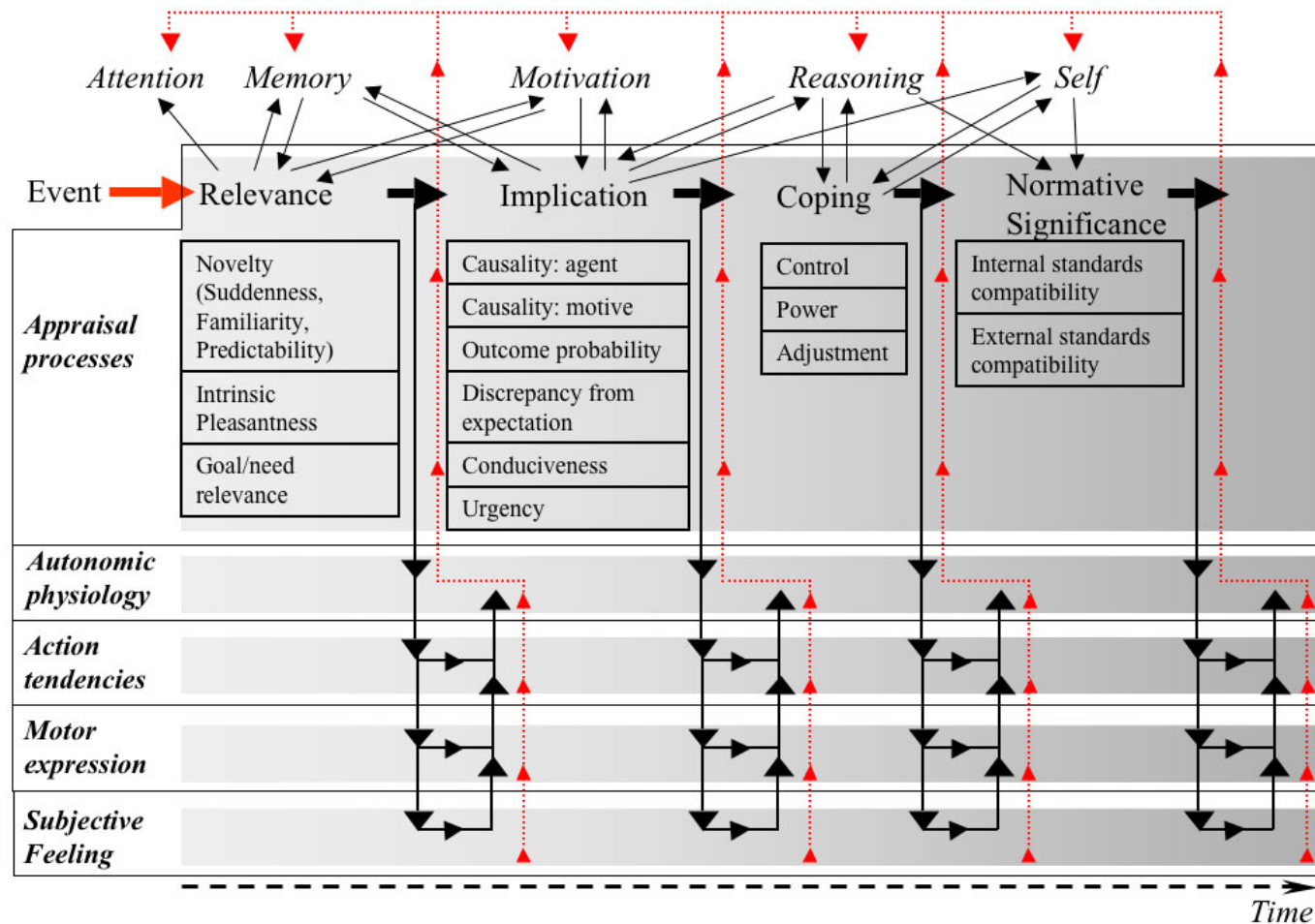

RELATION TO APPRAISAL (CPM)

- *Relevance*: Goals (PFC)/Novelty (PFC,HC,STR, DA)/Pleasantness (Value as expected reward: VTA, NAcc, OBFC, ACG)
- *Implications*: Outcome/error (Goals:PFC,MON:ACG, ongoing state: PL)/Causality/Expectancy (Forward models: PL, PFC)
- *Coping*: Goal & attention strengthening: PL, ACG, Limbic/Alternate strategies: Schemata (PFC, HC)
- *Significance*: Value/Ultimate Goals (PFC/HC)

Relation to Levels of CPM

- *Sensory-motor*: Hard-wired genetic (build on genetic templates in amygdala, brain stem)
 - *Schemata*: Learnt over time (under attention), coded in PFC/Post. CX as rules: automatic
 - *Conceptual Level*: Involves cultural meaning, and consciousness
 - *Consciousness model*: needed to model CPM
-

PEOPLE/PROJECTS INVOLVED

- Nickolaos Fragopanagos (KCL: ERMIS->BBSRC Emotional AB)
- Neill Taylor + Matthew Hartley (KCL: EPSRC Attention/ABC)
- Nienke Korsten (KCL/Antwerp: Language/Cb->HUMAINE)
- Andy Ioannides (BSI: MEG)
- Jane Raymond/Kim Shapiro/Nobre/Eimer (BBSRC: Emotional AB by fMRI/EEG/MEG)
- Kaustubh Chokshi/Christo Panchev (GNOSYS: cognitive robotics + Genoa/Crete/Athens/Tubingen)
- Jonathan Howard (IOP: cognitive robotics)

1. ATTENTION IN THE BRAIN

- ACTS AS A FILTER TO PRODUCE AN 'ATTENDED STATE OF THE WORLD'
 - VERY IMPORTANT TO HAVE 'GOOD' ATTENTION: LACK => MANY PROBLEMS IN ENVIRONMENT
 - ACCIDENTS/ POOR WORK/ DANGER TO OTHERS
-

- **ATTENTION: SITES WITH 2 FUNCTIONS:**

- * **AMPLIFY/DECREASE SENSORY INPUT**

- * **CREATE CONTROL SIGNALS FOR THIS:**

“Attention-related activity in frontal and parietal areas does not reflect attentional modulation of visually evoked responses, but rather the attentional operations themselves.”

(Kastner & Ungerleider, 2001)

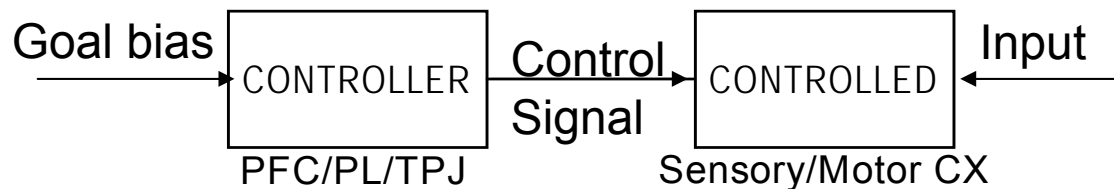

Outline of Visuo-Motor Control System (JGT + NF, IJCNN'03)- ballistic only

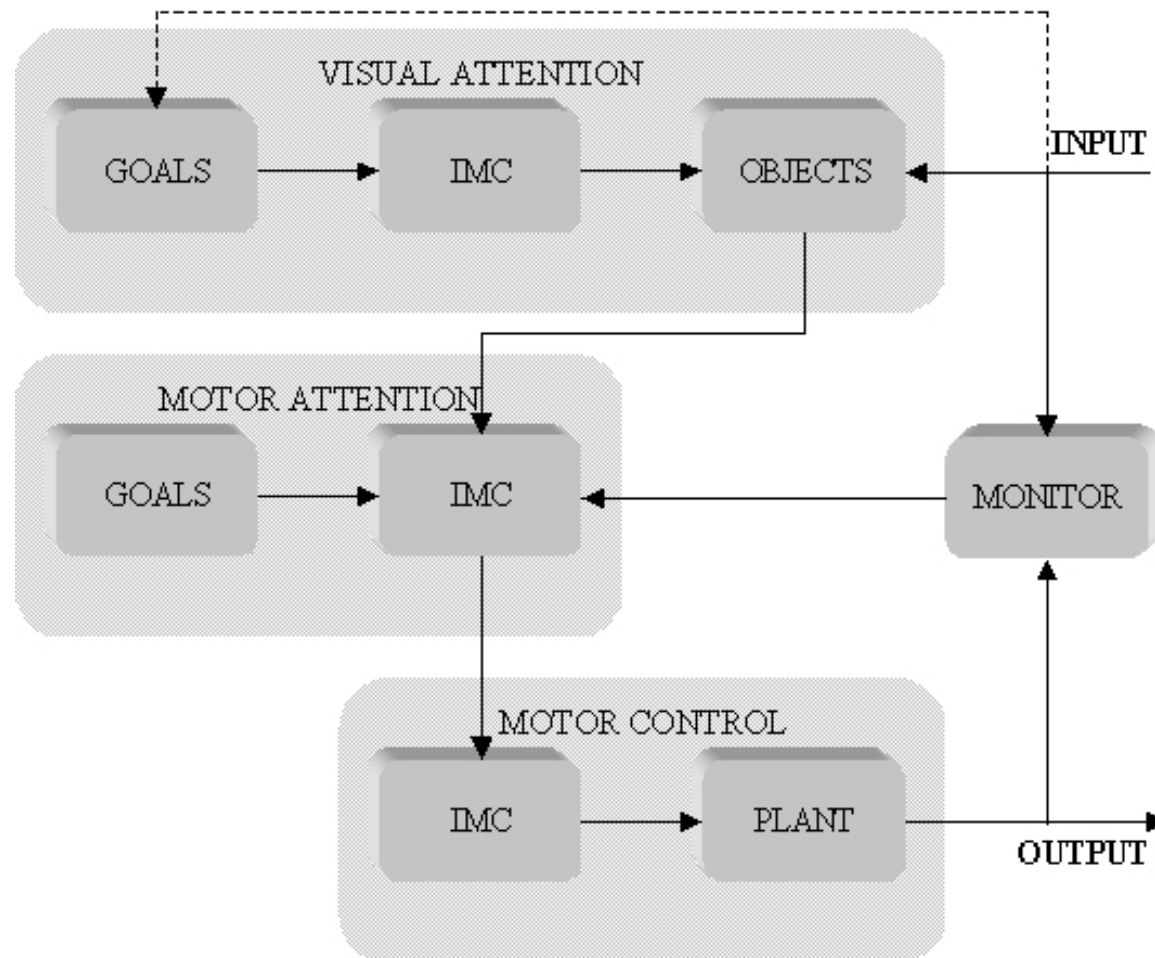

CODAM Architecture: monitor achieves damage limitation in IMC: AB Model by NF+SK+JGT in Cog Brain Res, 2005)

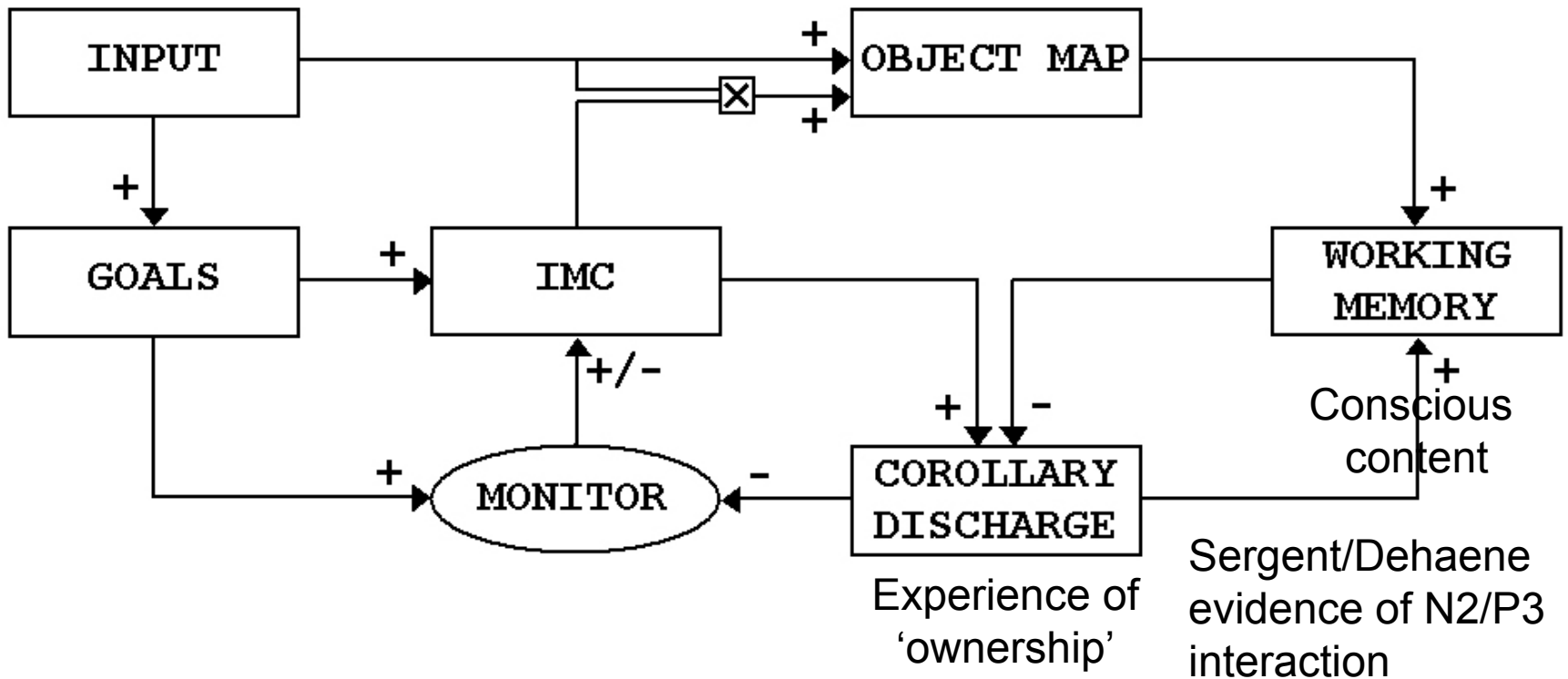

2. EMOTIONS IN THE BRAIN

- **Emotion = automatic or attended**
 - **Automatic: Limbic regions (amygdala, hypothalamus,) + body (GSR, BP,...)
= valence (limbic +/- reward codes) +
arousal level + approach/retreat**
 - **= 'standard story'
(emotion in amygdala with no attn)**
-

Facial Emotion Recognition Circuit: (Adolphs, 2000)

Automatic route to amygdala →
?

Part of
'standard story'

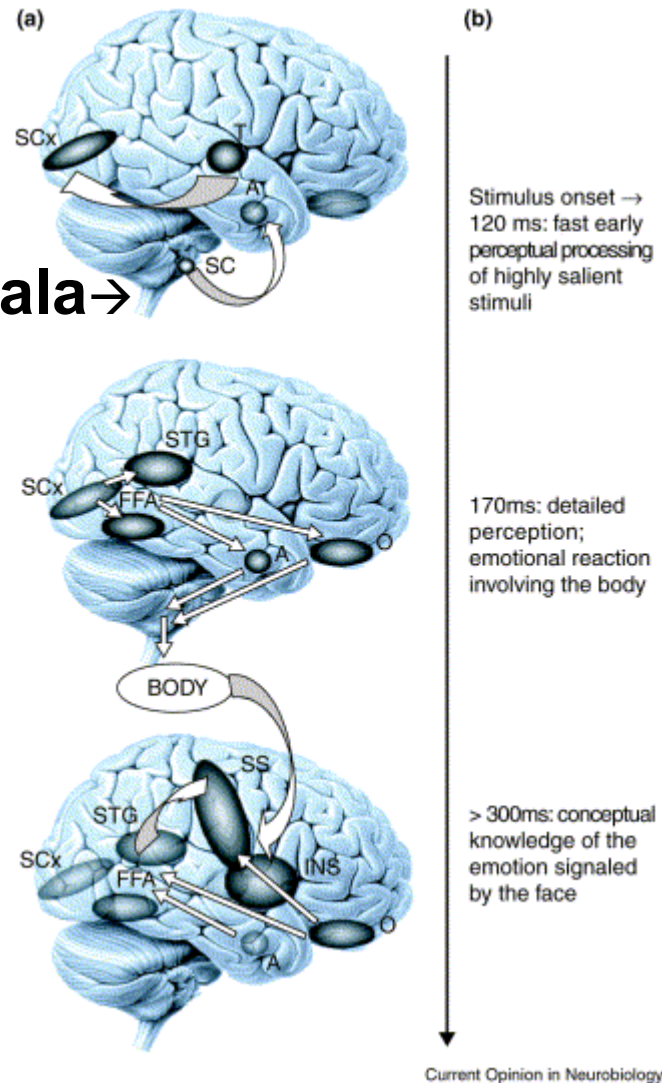

■ **Conclusions on Emotion System:**

- **AMYGDALA ↔ CX (VCX/TL/OFC)**
 - ⇒ **automatic bias attention by valence**
- **ORBITOFRONTAL CX:**
 - valence codes from amygdala/VTA/STR**
 - ⇒ **influence behaviour via OBFC ↔ PFC**
- **Depression model of Mayberg (ACG bridge)**

3 EMOTION v ATTENTION CIRCUIT

- Valence in amygdala & OBFC
- Attention in parietal & PFC
- Interaction in ACG
- Other interaction?

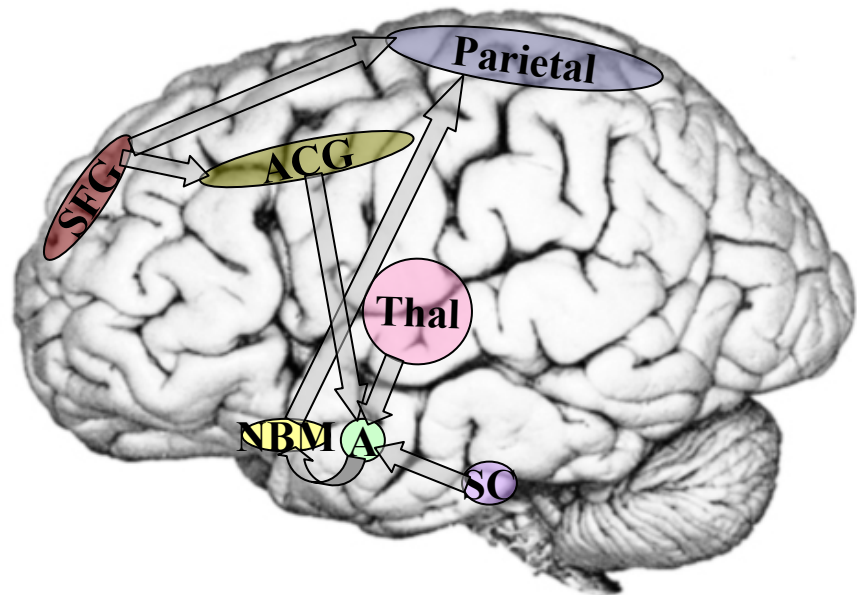

■ EXTENDED ATTENTION V EMOTION ARCHITECTURE:

(extend Corbetta & Shulman, 2002)

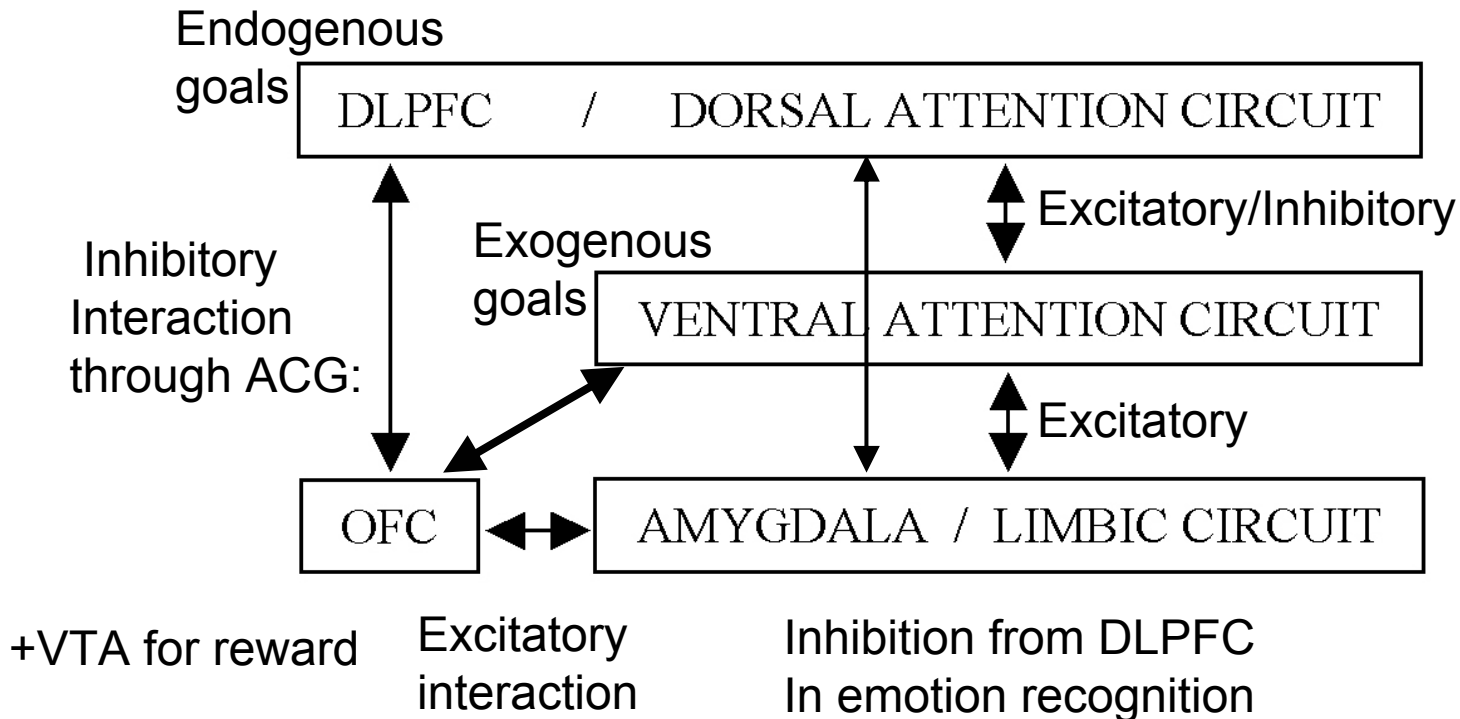

Awareness v Not (on extinction patient GK: Vuilleumier et al, 2002)

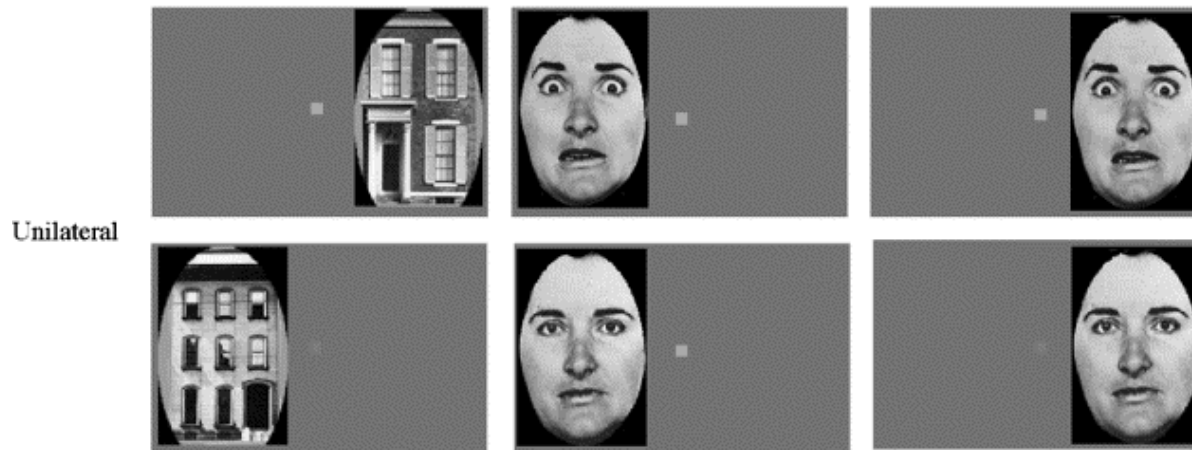
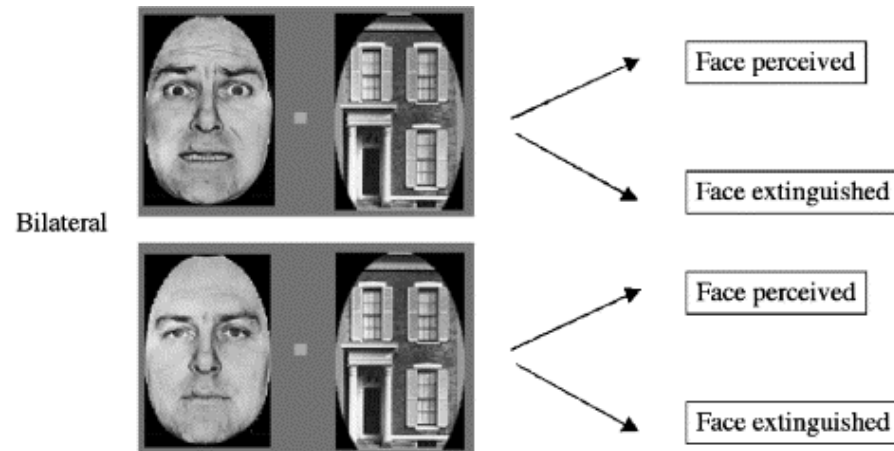

Results: awareness unimportant in L AMYG & OBFC, but is so in R Fusiform

Gyrus Face area:
included in
simulations, as
far as awareness
arising from
attention by
CODAM

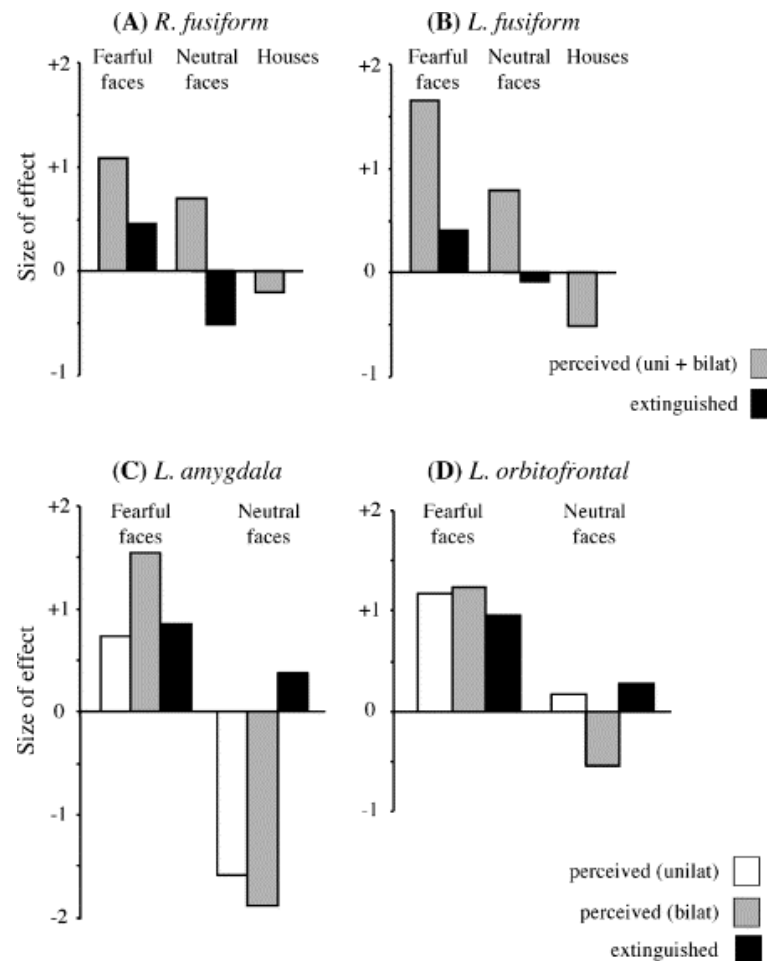

Interaction of OBFC v DLPFC (Perlstein et al, PNAS.2002)

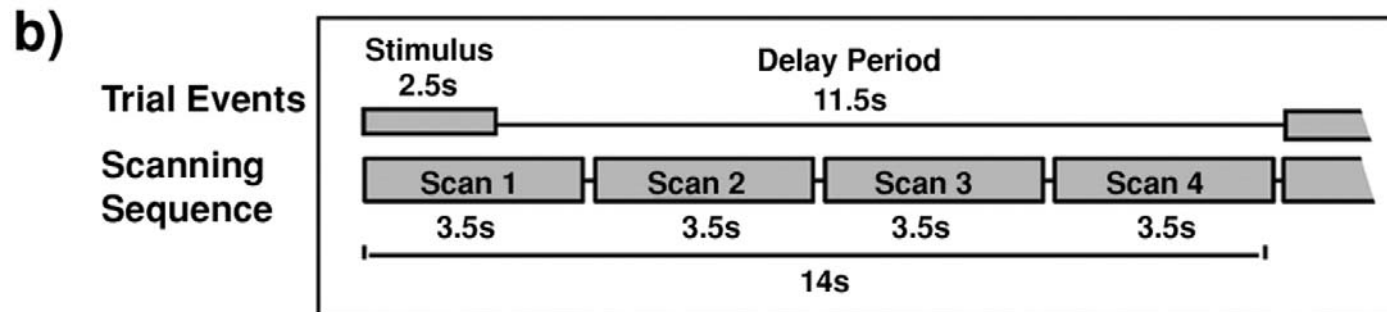
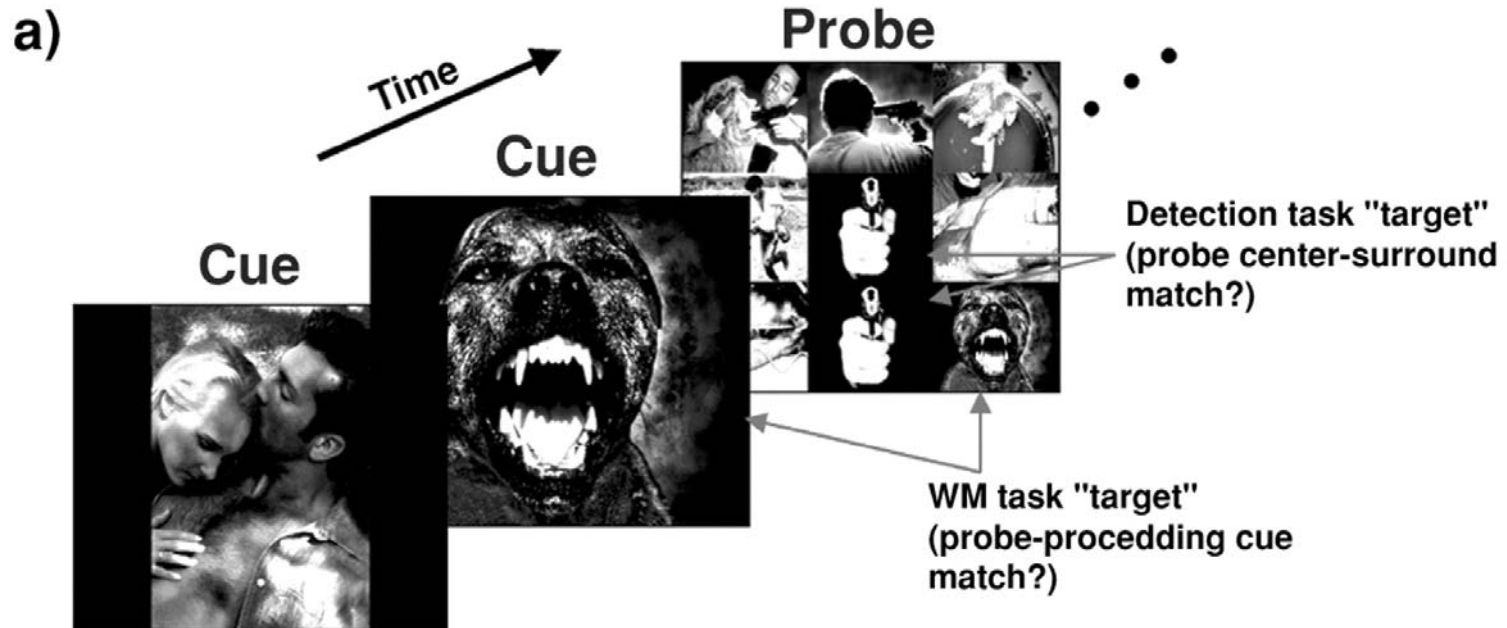

Results: DLPFC ↔ OBFC is inhibitory in WM (with pleasure handled by DLPFC: relevant to depression, when DLPFC ↓)

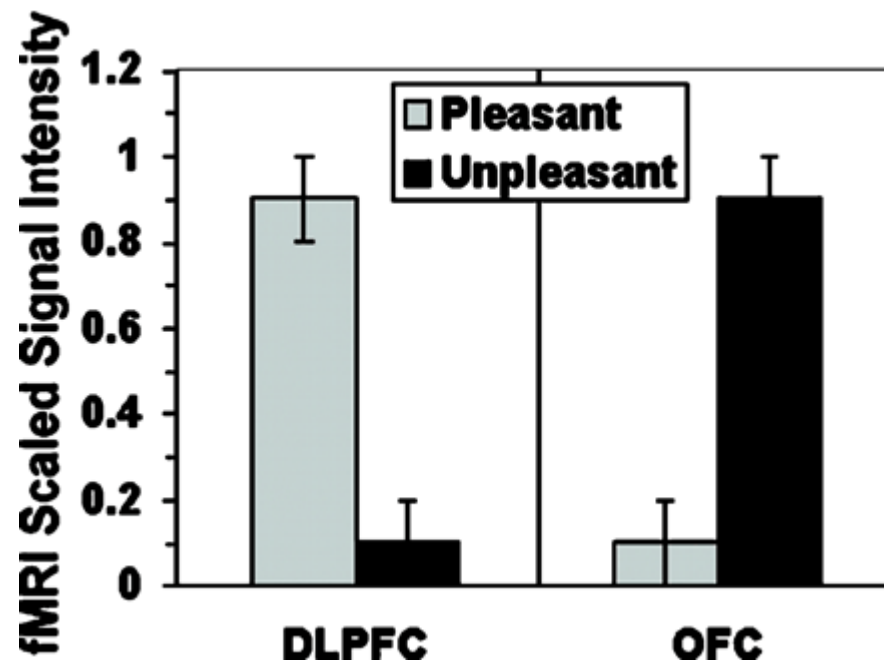

4. SIMULATING EMOTIONS: PESSOA ET AL (PNAS 2002)

/ **fa + ce(emotional) \ (200ms)**

- Cndn1: classify orientation of bars 64%
- Cndn2: identify gender of face 91%
- Results:
 1. faces attended => amygdala active,
 2. faces unattended => amygdala inactive

=> NOT STANDARD PICTURE OF EMOTIONS

SIMULATION (NF & JGT, BICS'04)

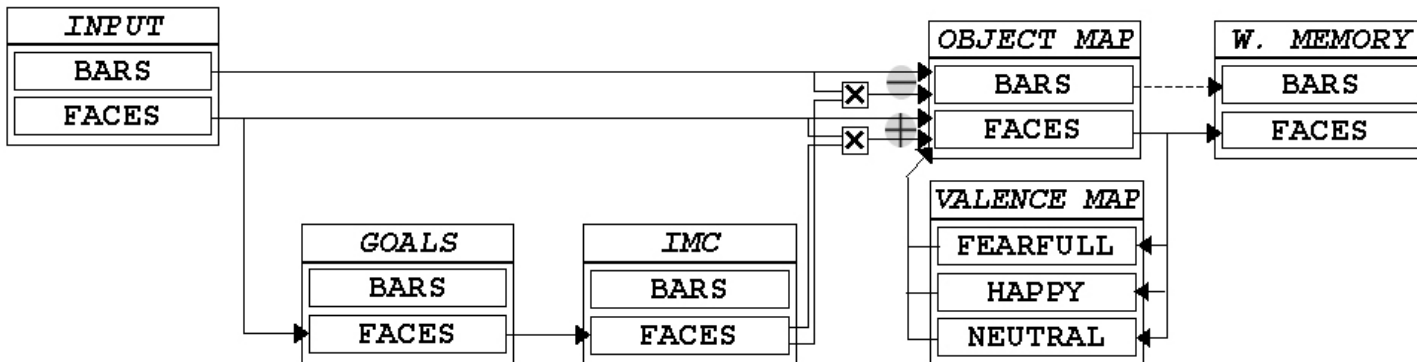

DETAILED ARCHITECTURE FOR FACES CLASSIFICATION gender

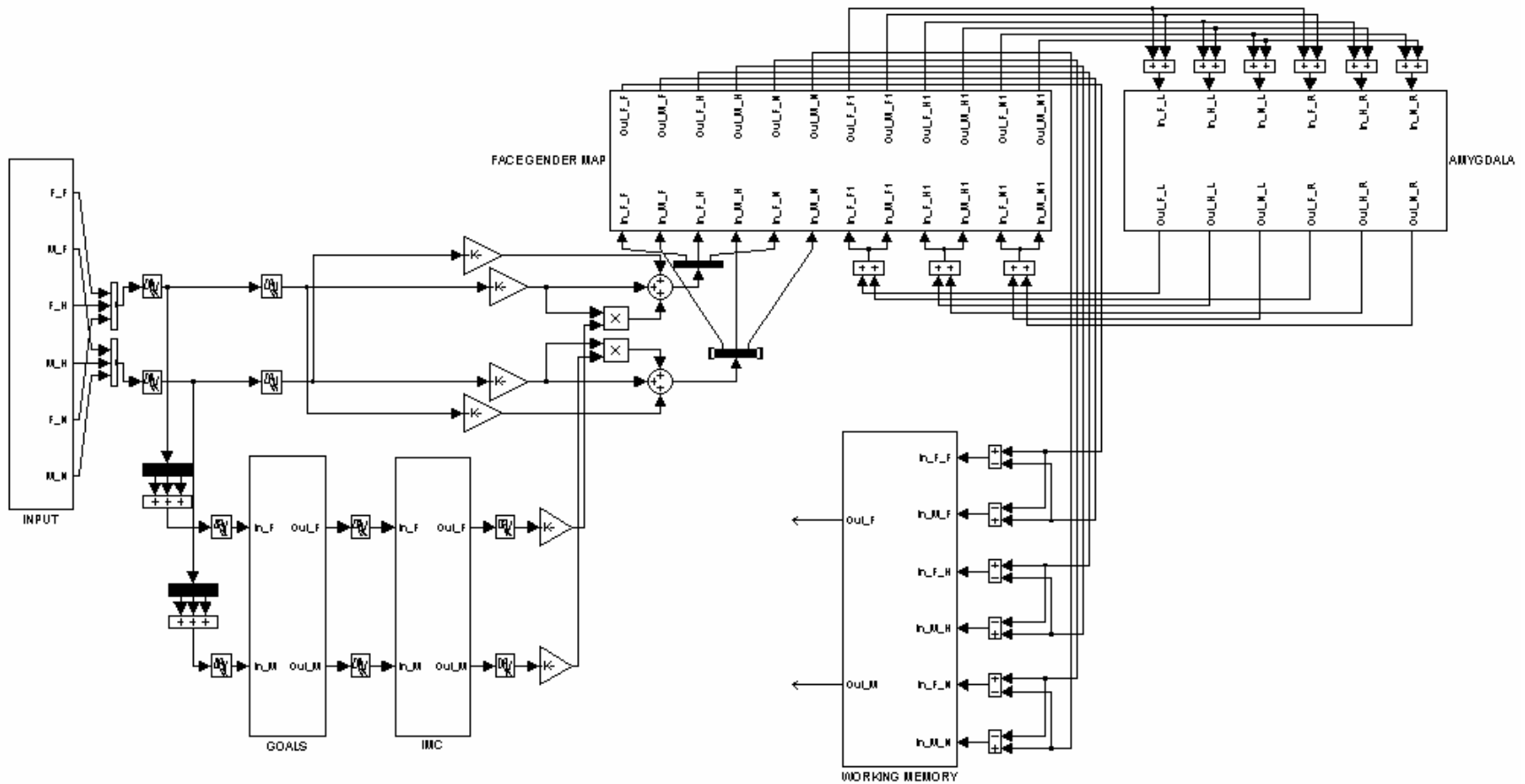

Amygdala simulation (LFPs \rightarrow fMRI BOLD by convolution with Gaussian in time) \approx real data

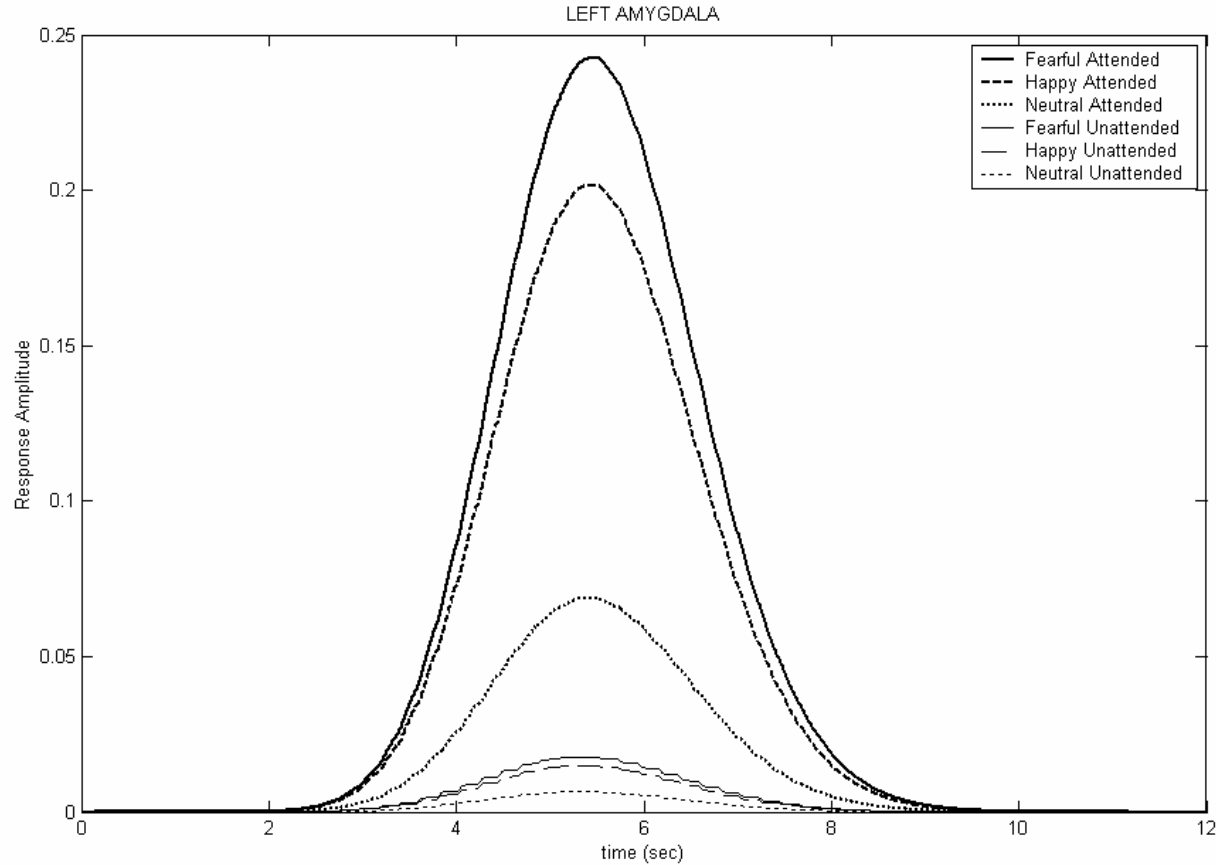

For fusiform face area \approx real data

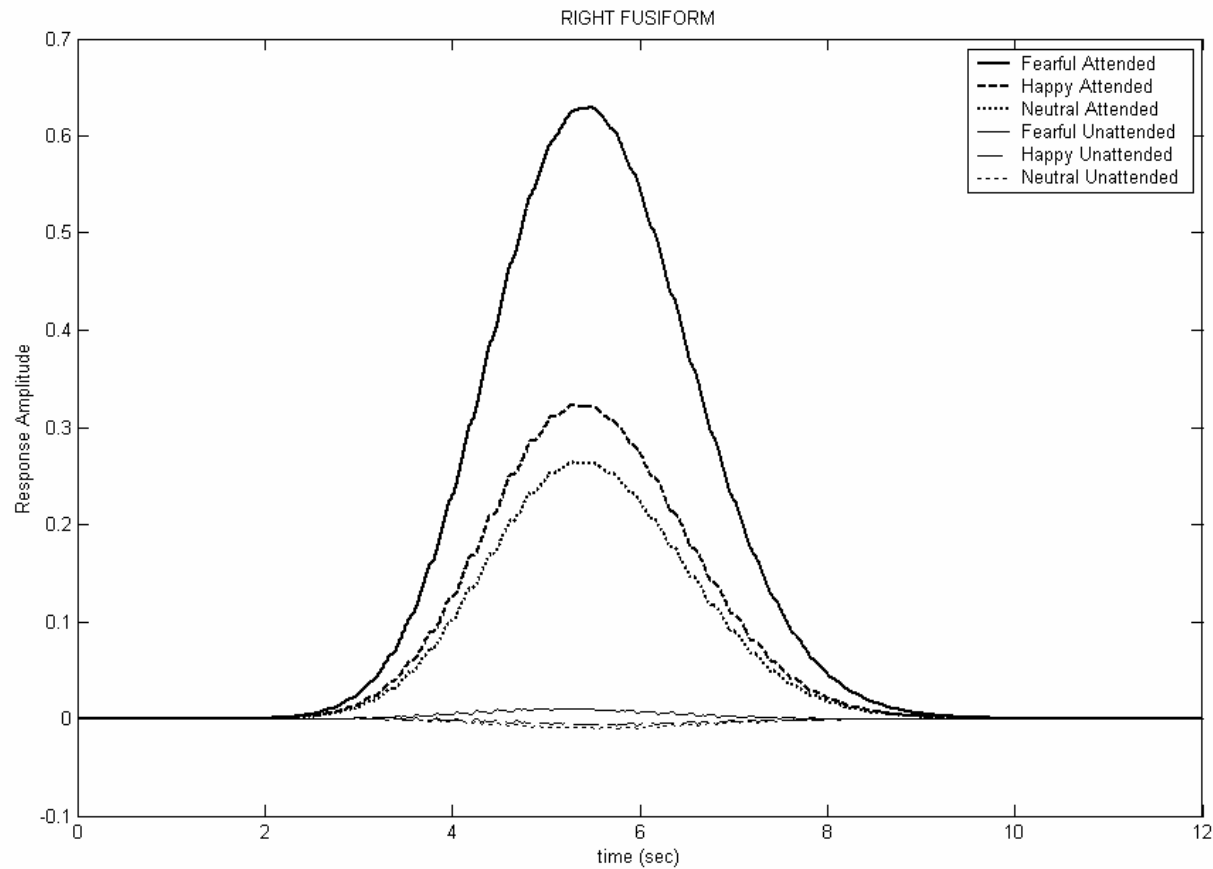

2) YAMASAKI ET AL (2002)

- **Targets = circles (8%)**
 - **Standards = squares (84%)**
 - **Classify stimuli: targets v others**
 - **Distracters = neutral stimuli (4%)**
= emotional stimuli (4%)
 - **RT > RT to all other stimuli**
 - **Explain: inhibit cognitive goals (in DLPFC) by valence (in AMYG/OBFC)**
-

ARCHITECTURE FOR SIMULATION

(Simple model of depression, but needs addition of CG to develop more fully)

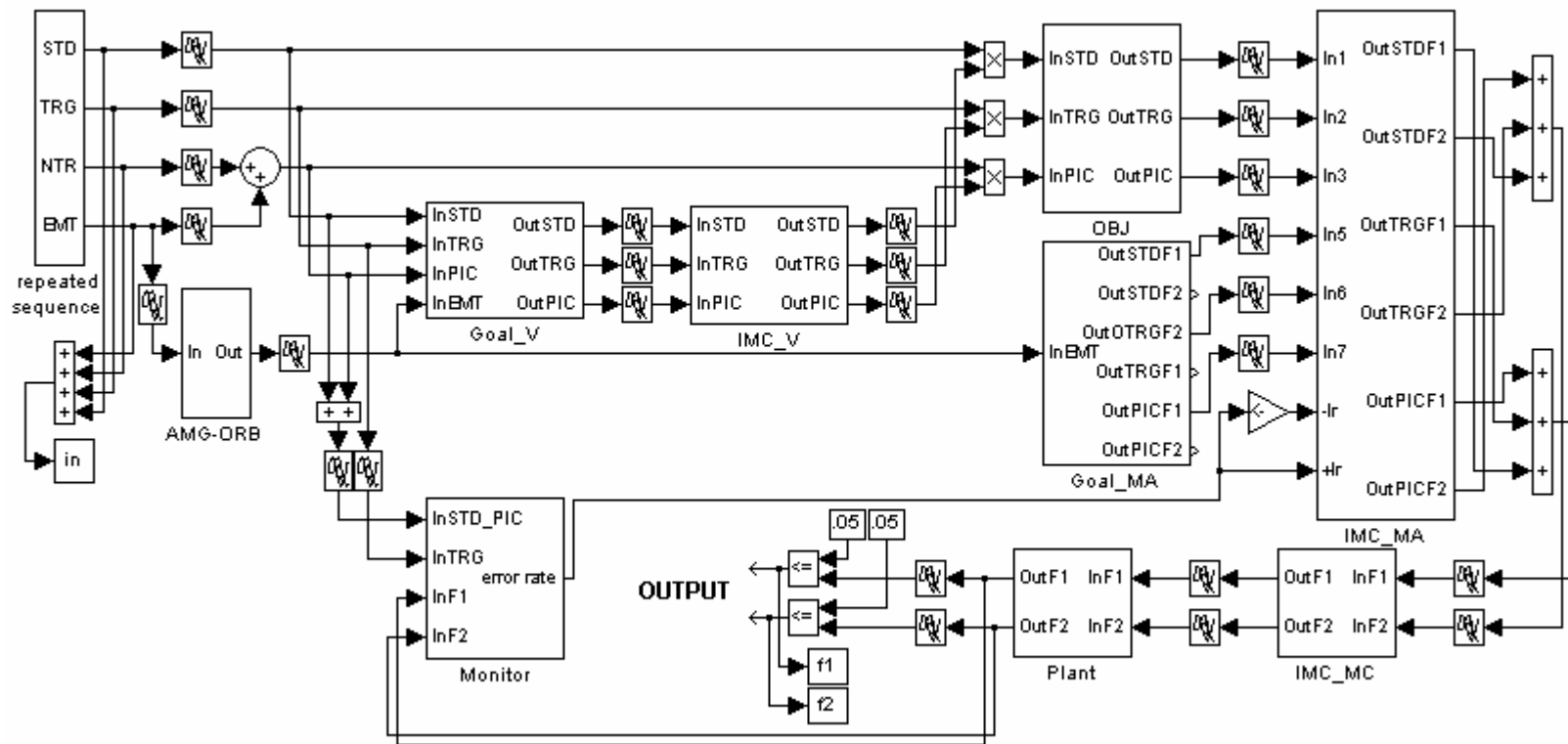

DATA

<i>Type of Input</i>	<i>Description of Input</i>	<i>Freq of Input</i>	<i>RT (ms)</i>
Standards	Squares of various sizes & colors	84%	536
Targets	Circles of various sizes & colors	~8%	691
Emotional	Unpleasant pictures	4%	<u>728</u>
Neutral	Neutral pictures	4%	<u>680</u>

SIMULATION RESULTS

- **Simulation has slowing ~50ms (inhibition of goal signal by emotional input in ventral PFC)**
- **≈ Data (50 ms)**
- **SIMULATE OTHER EXPERIMENTAL RESULTS**

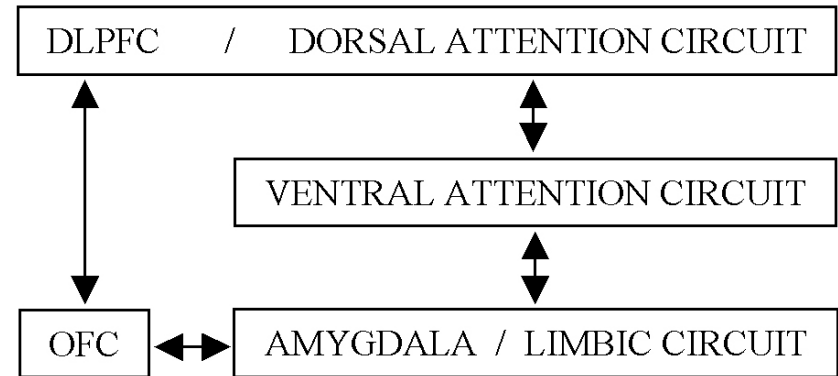

5. CONCLUSIONS: General

1. **Emotion biases attention thro' amygdala: AMYG→OBJ (boost for report), AMYG→IMC (drags attn if unattended)**
2. **Cognition in DLPFC ↔ Valence as LTM in OFC/ altered rapidly in AMYG**
3. **Cognition ↔ Emotion also through CG (Mayberg): need to model interaction (and DBS of subgenual CG+ACG)**
4. **Value map outside direct attention control**
5. **(although have OBFC↔DLPFC inhibition)**
6. **Need to relate to CPM**

Conclusions: Emotion v Cognition

- OBFC ↔ DLPFC is inhibitory (Perlstein et al)
 - OBFC is activated without attention (Vuilleumier et al)
 - Future reward predictions in OBFC thus out of direct influence of attention
 - OBFC sources of emotion mainly controlled cognitively by DLPFC (through mutual inhibition)?
-